

JOHN DEERE 6068TFM50

> 175 HP (130 KW) @ 2400 RPM

- > Water cooled exhaust manifold
- > High torque
- > Low RPM
- > Heat exchanger or keel cooling
- > Low noise and vibrations

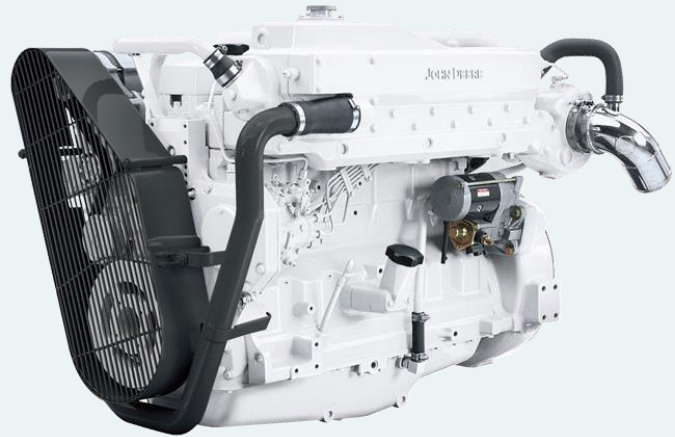

John Deere Propulsion

6068TFM50 is a classic and robust turbo engine. It has a mechanical fuel pump can be supplied with keel cooling or heat exchanger. The exhaust manifold is water cooled, resulting in low surface temperatures and reliable operation. 12 or 24 volt electrical system, with Nogva Motor Computer monitoring system.

Technical Specifications

Rated power*	175 / 130 (hp / kW)
Engine speed*	2400 RPM
Displacement	6800 cm ³
Number of cylinders	6 in-line
Bore and stroke	106 x 127 mm
Compression ratio	17:1
Governor type	Mechanical
Aspiration	Turbocharged
Cooling system	Heat exchanger or Keel cooling
Electrical system	12 or 24-volt
Max. Install angle	12°
Weight (dry)	730 kg
Rating	M2
Emission rating	None
Connections	
Exhaust, wet	Min Ø113 mm
Exhaust, dry	Min Ø100 mm

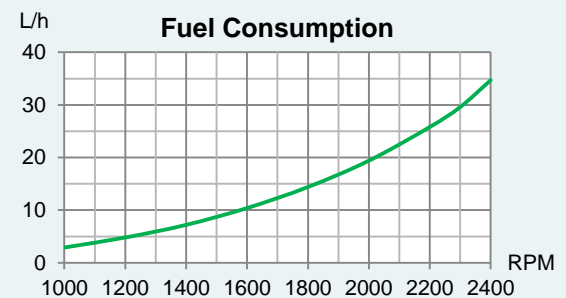
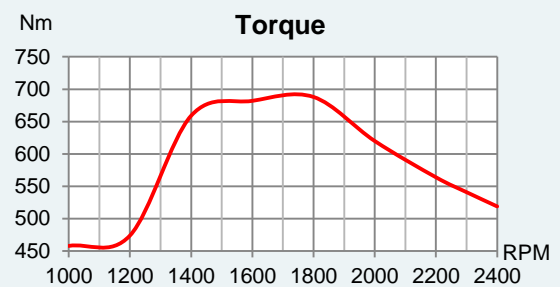
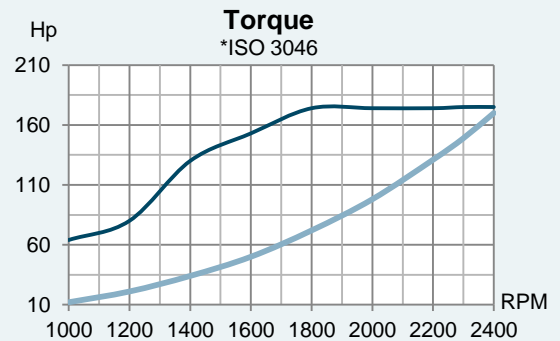

JOHN DEERE 6068TFM50

Standard equipment

- > Nogva Motor computer
- > With external cooling pipes or heat exchanger
- > Silencer (Dry exhaust)
- > Exhaust compensator
- > 2-pole complete el.system (12/24V)
- > Extension cable for computer (4m)
- > Bilge pump for lub.oil
- > Engine brackets
- > Water cooled turbo and manifold
- > Water separator (fuel)

Optional equipment

- > Nogva marine gear
- > Nogva CPP propeller
- > Vibration isolators
- > Control lever
- > Control cable
- > Pulley/adapter for front equipment
- > Other equipment on request

Dimensions

