

NOGVA GEAR HCA-210

> 37,7 HP @ 100 RPM (3.03:1)

- > Servo for CPP
- > Optional with 1 or 2 PTO's
- > Propeller shaft break built in
- > Hydraulic multiplate clutch
- > Controlled in test bench
- > More than 3000 gearboxes on the market

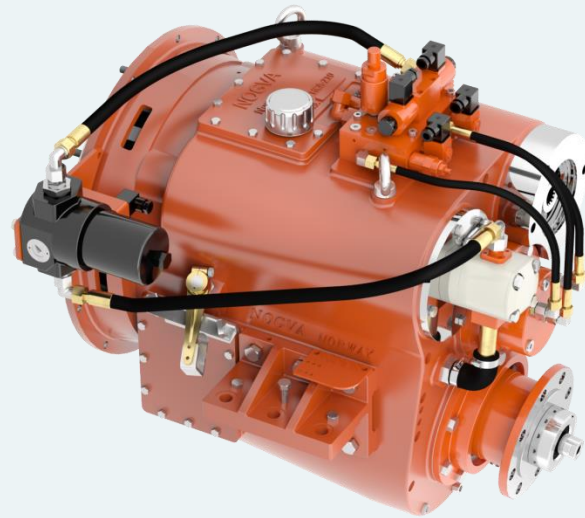

Nogva Gear

Built-in servo for CPP. Construction in rigid cast iron house, helical gearwheels, conical roller bearings and hydraulic multiplate clutch. Individually controlled in test bench.

Technical specifications	
Connection flange	SAE 1
Flexible coupling	SAE 14"
Weight with 1 PTO	395 kg (SAE 1)
Weight with 2 PTO	405 kg (SAE 1)
Servo force	61 500 N
Servo stroke	85 mm
Rotation (outgoing shaft)	Clockwise
Maximum torque	
Reduction	Torque
1.52:1	2730 Nm
2.06:1	2180 Nm
2.37:1	1910 Nm
2.78:1	1550 Nm
Power take off (PTO)	
Ratio	1:1.5
Torque	233 Nm
Max power	78 kW
Flange	SAE C 12/24 DP (standard)
Pump rotation	Clockwise

Performance curve

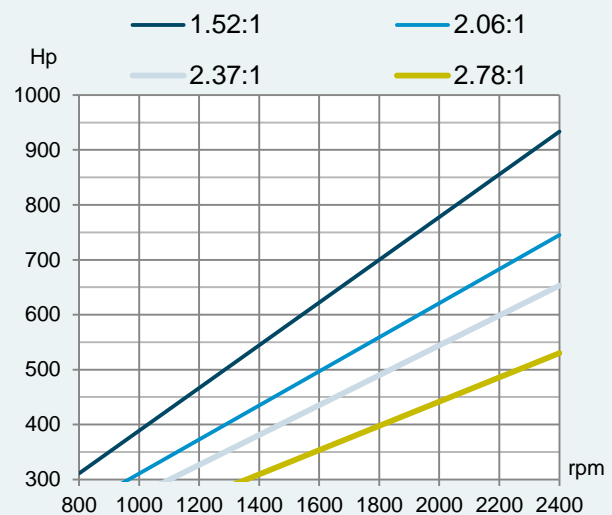

Performance curve

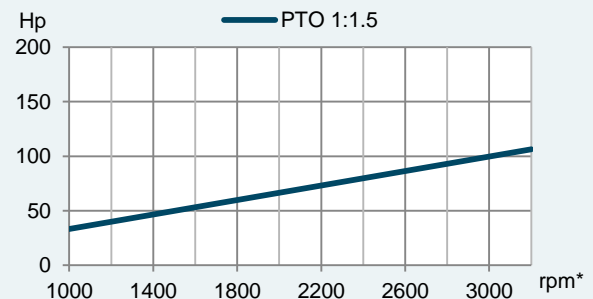

*rpm on PTO

NOGVA GEAR HCA-210

Standard equipment

- > Oil pump
- > Oil cooler
- > Oil filter
- > Flexible coupling

Optional equipment

- > Nogva CPP
- > HC-gear control
- > Monitoring (oil temp./pressure)

Dimensions

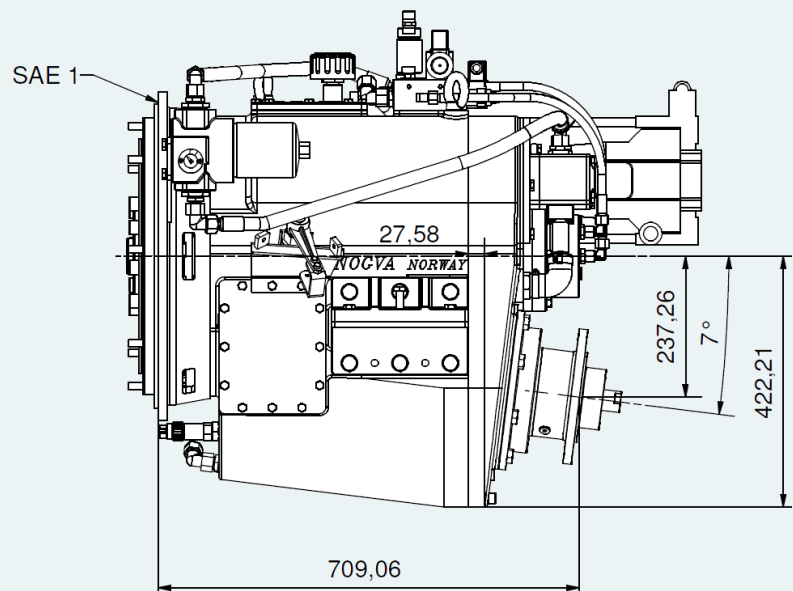
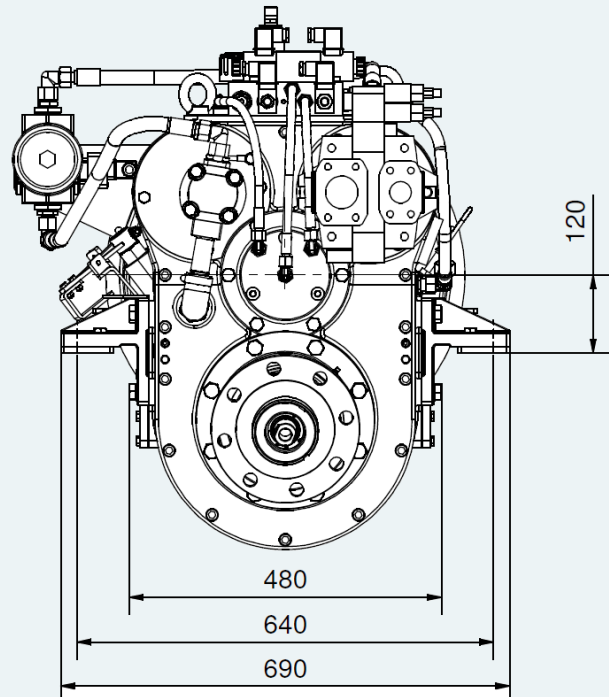

* SAE 1 and SAE 2