

# CUMMINS QSK38-M

> 1350 HP (1007 kW) @ 1900 RPM

- > Water cooled turbo and exhaust manifold
- > High Pressure Common Rail
- > High torque
- > Low RPM
- > Heat exchanger or keel cooling

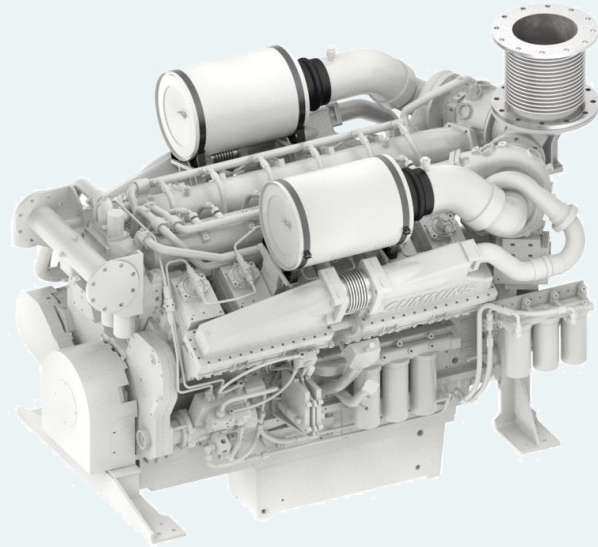

### Cummins Framdrift

QSK38 has 12 cylinders (V12) with Modular High Pressure Common Rail Fuel System, which provides good fuel economy and low emissions. The air intake is turbocharged. Water cooled exhaust manifold lowers the surface temperature of the engine and ensures reliable operation. High torque gives good response when maneuvering and low rpm reduces noise and vibration levels. 24-volt electrical system with Nogva Motor Computer monitoring system. The Q-Series was launched in 2005, designed to meet current and future stringent environmental requirements.

### Technical Specifications

Rated power*	1350 / 1007 (hk / kW)
Engine speed*	1900 o/min
Displacement	37900 cm <sup>3</sup>
Number of cylinders	V12
Bore and stroke	159 x 159 mm
Compression ratio	15:1
Fuel injection	High Pressure Common Rail
Aspiration	Turbocharged and aftercooled
Cooling system	Heat exchanger or keel cooling
Electrical system	24-volt
Weight (dry)	4640 kg
Rating	Heavy Duty
Emission rating	EPA Tier 2, IMO Tier 2 and EU Stage 3a

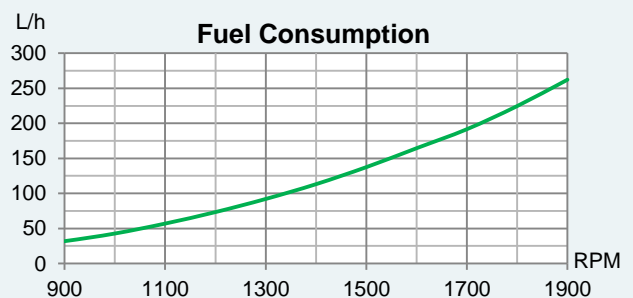
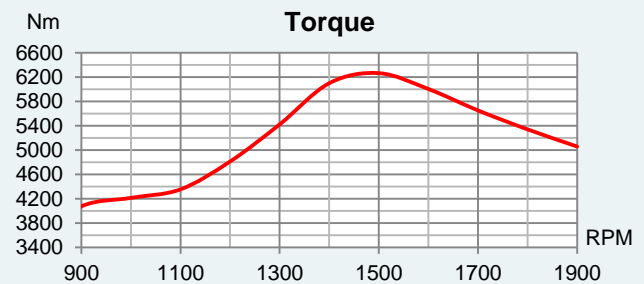
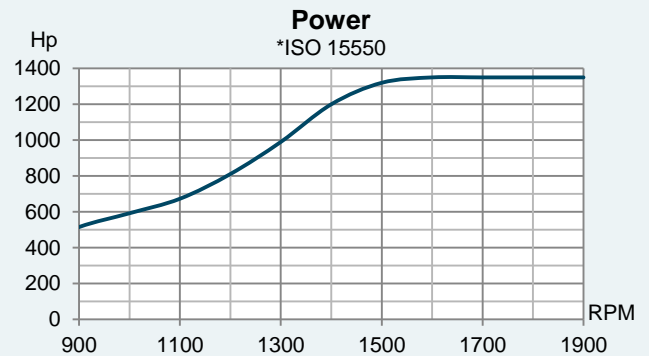

# CUMMINS QSK38-M

## Standard equipment

- > Nogva Motor computer
- > Keel cooling configuration
- > Silencer (Dry exhaust)
- > Exhaust compensator
- > 2-pole electrical system (24V)
- > Extension cable for computer (8m)
- > Bilge pump for lub.oil
- > Engine brackets
- > Water cooled turbo and manifold
- > Water separator (fuel)

## Optional equipment

- > Propeller system and gear
- > Keel cooler
- > Heat exchanger
- > Control lever
- > Control cable
- > Front mounted PTO
- > Other equipment on request

## Dimensions

