

SCANIA DI16 074M

> 511-596 kW @ 1500-1800 RPM

- > Unit injector
- > Wet cylinder liners
- > Separate cylinder heads
- > Excellent fuel economy
- > Low emissions

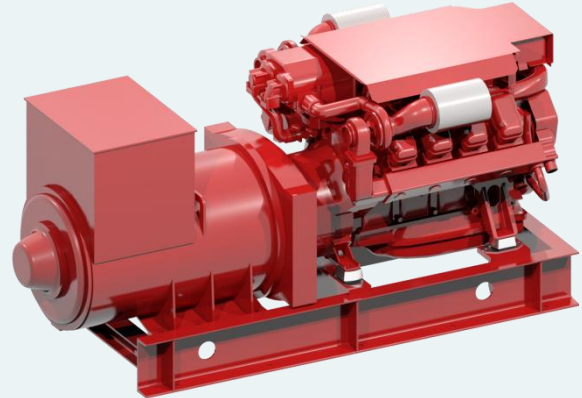

Scania Auxiliary Engine

Scania marine engines are designed for strength and durability. The basis of the design is an optimized cylinder block with replaceable water-cooled cylinder liners.

Individual cylinder heads with four valves per cylinder offers easier service and access for repairs. The engine is controlled by Scania EMS system that monitors the engines systems and verifies that the correct amount of fuel is delivered through the engines electronically controlled unit injectors. Scania EMS ensures low fuel consumption and the cleanest possible exhaust. The engine is type approved by the major classification societies and meets the current environmental standards.

Standard equipment

- > Nogva Motor Computer V2-G
- > Electronic regulation
- > 2-pole electrical system
- > Heat exchanger
- > Exhaust compensator
- > Silencer
- > Bilge pump for lub.oil
- > Engine brackets
- > Water cooled manifold
- > Vibration isolators
- > Base frame in steel
- > Heat elements in generator
- > With droop transformer for parallel operation
- > Closed crankcase ventilation with filter

Optional equipment

- > Electric seawater pump
- > Engine heater

Rated power and fuel consumption

<i>RPM / Hz</i>	<i>1500 / 50</i>	<i>1800 / 60</i>
Generator effect	511 kW	596 kW
Torque	3253 Nm	3162 Nm
Fuel Consumption 100%	199 g/kWh	202 g/kWh
Fuel Consumption 75%	200 g/kWh	204 g/kWh
Fuel Consumption 50%	202 g/kWh	205 g/kWh
Emission ratings	EU Stage IIIa US Tier 2 and IMO Tier II	

SCANIA DI16 074M

General Data		Exhaust System		
Model	DI16 074M	RPM / Power	1500 / 511 kW	1800 / 596 kW
Number of cylinders	V-8	Exhaust temperature	473 °C	447 °C
Engine type	4-cycle	Exhaust flow	80,3	100,0 m ³ /min
Aspiration	Turbocharged	Air consumption	30,4 m ³ /min	39,7 m ³ /min
Bore and stroke	130 x 154 mm	Heat rejection		
Displacement	16,4 L	To coolant*	376 kW	449 kW
Compression ratio	16,7:1	To main coolant circuit**	---- kW	---- kW
Injection system	Unit injector, PDE	To charge air cooler circuit**	---- kW	---- kW
Oil capacity	Min 40 - Max 48 liter	To exhaust gas	312 kW	376 kW
Oil change intervals	500 hours	To surrounding air	24 kW	29 kW
Oil cleaner	Centrifugal and filtration	Cooling System	HE	KC
Electrical system	2-pole, 24V, DC	Coolant capacity	63 L	50 L
Starter (standard)	2-pole, 24V, 7kW	Coolant temperature	86-91 °C	78-83 °C
Alternator (standard)	2-pole, 28V, 100A	Opening temperature	80/87 °C	75 °C
Weight with HE	1670 kg	Coolant flow @ back pressure in CAC circuit**	L/min @ bar 200 @ 0,5	L/min @ bar 240 @ 0,7
Weight with KC		Coolant flow @ back pressure in main circuit	L/min @ bar 370 @ 0,5	L/min @ bar 460 @ 0,7

*Heat exchanger engines (HE) - **Keel cooled engines (KC)

Dimensions with Stamford HCM634GHJK-2

